



CORGHI LIFTS SPRING SALE LIMITED STOCK



CORGHI ERCO 4004 SERIES - 4 POST LIFTS

- Special solutions have been used to create lifts with a maximum load capacity of 4000 kg together with a minimum ground height of just 126mm.
- The lifts with wheel alignment have large runways that make it possible to lift most vehicles without having to frequently adjust the mobile runway. The 2,950 mm spacing between the posts ensures complete compatibility with 3D wheel aligners.
- The four column lifts series "ERCO4004-5004" are electrohydraulically operated.
- Safety devices directly activated by 4 electromagnets which increase the operation speed and safety.
- Better utilisation of the internal spaces, reduced overall dimensions, four independent cables.
- All devices prescribed by the CE norms and existing regulations.

Max. load	4000 - 5000 kg
Lifting/lowering time	40/40 s
Pneumatic power supply	4 - 10 bar
Motor power	2.6 (400V 3ph 50Hz)
Power supply	230-400V 3ph 50-60Hz
Max. capacity	3500 kg

Ref. No.	Description	Content
0-43102502/15	CORGHI ERCO 4004BCT	1
0-43103701/15	CORGHI ERCO 4004WCT	1



ERCO 4004 WCT
WHEEL ALIGNMENT RUNWAYS

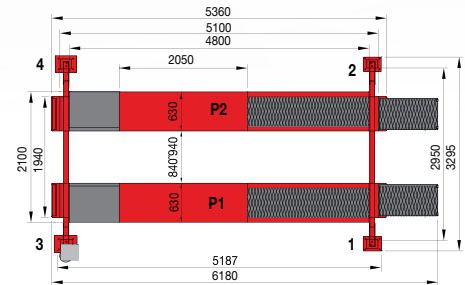
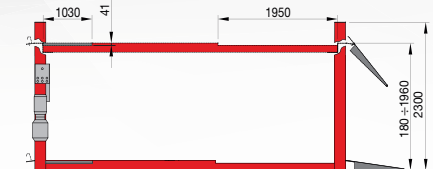

ERCO 4004 BCT
LOW PROFILE, RECESSED RUNWAYS FOR WHEEL ALIGNMENT

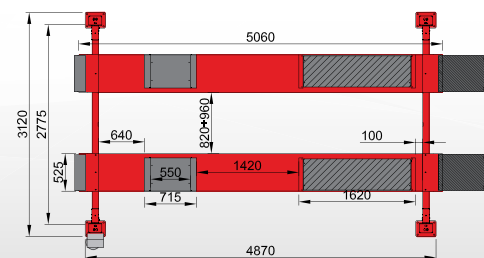
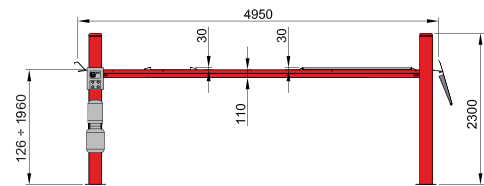

FROM:
£36.55 PER WEEK*

ERCO 4004 BCT

ERCO 4004 WCT

£4,520.00+VAT
PROMOTION

£5,250.00+VAT
PROMOTION

£36.55+VAT
PER WEEK. 3YR LEASE
SUBJECT TO STATUS

£42.45+VAT
PER WEEK. 3YR LEASE
SUBJECT TO STATUS

*ALL PRICES SUBJECT TO VAT, DELIVERY AND INSTALLATION.

*LEASE PRICES ARE SUBJECT TO STATUS AND VAT. PRICES PER WEEK, 3 YEAR LEASE.



FINANCE OPTIONS ✕ SERVICE CONTRACTS 7 ACCESSORIES 🛡️ 2 YEAR WARRANTY 🚚 DELIVERY AND INSTALLATION



exclusively distributed by REMA TIP TOP in Great Britain

0113 2770044
WWW.REMA-TIPTOP.CO.UK

CORGI ERCO H3202 SERIES - 2 POST LIFTS

- Electrohydraulic two-post lifts with 3-stage and extra-flat symmetrical arms.
- The H3202 range lifts are operated by a master/slave type hydraulic circuit with automatic realignment of the two trolleys at each lifting cycle; thanks to this circuit, the H3202 range lifts are particularly reliable, easy to install and do not require mechanical adjustments after the first installation (there are no metal ropes between the columns).
- Automatic braking exclusion button. This function makes it possible to lower the lift without the initial upward step.

Max. capacity	3200 kg
Lifting time	30 s
Lowering time	34 s
Electric motor power	2.6 (400V 3ph 50Hz)
Power supply	230-400V 3ph 50-60Hz
Control circuit tension	24 V



Ref. No.	Description	Content
0-43102203/15	CORGI ERCO H3202 V	1
0-43102204/15	CORGI ERCO H3202 CBP	1

FROM:
£22.23 PER WEEK*

ERCO H3202 V OVERHEAD PIPES

£2,750.00+VAT
PROMOTION

£22.23+VAT
PER WEEK. 3YR LEASE
SUBJECT TO STATUS

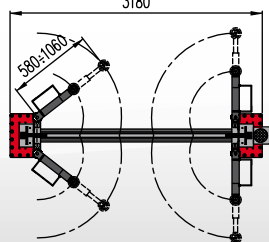
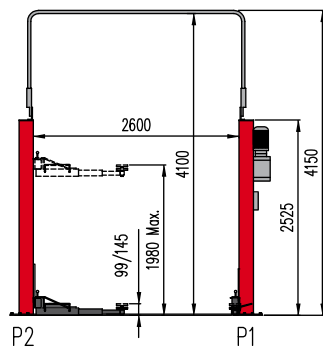

ERCO H3202 CBP VERSION WITH BASE

£2,950.00+VAT
PROMOTION

£23.85+VAT
PER WEEK. 3YR LEASE
SUBJECT TO STATUS

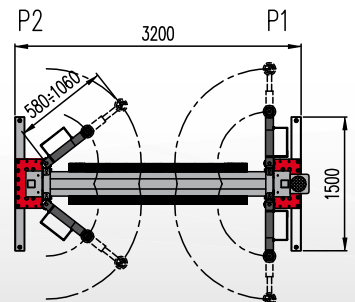
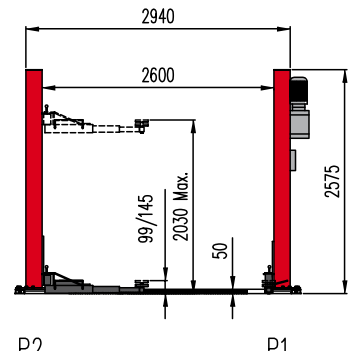

*ALL PRICES SUBJECT TO VAT, DELIVERY AND INSTALLATION.

*LEASE PRICES ARE SUBJECT TO STATUS AND VAT. PRICES PER WEEK, 3 YEAR LEASE.



FINANCE OPTIONS
 SERVICE CONTRACTS
 ACCESSORIES
 2 YEAR WARRANTY
 DELIVERY AND INSTALLATION



exclusively distributed by REMA TIP TOP in Great Britain

0113 2770044

WWW.REMA-TIPTOP.CO.UK